

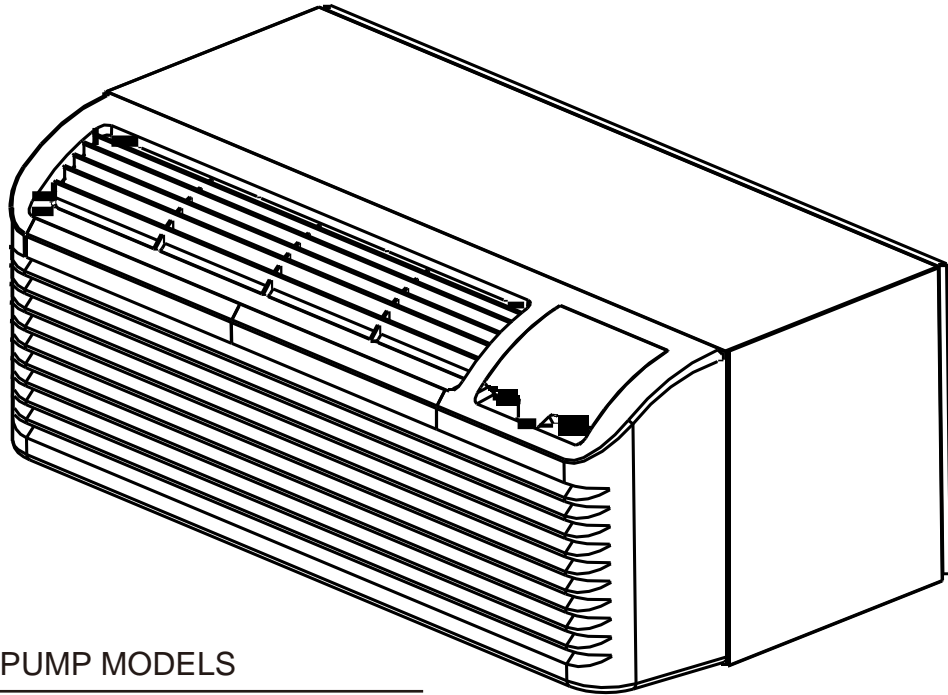

DC-INVERTER PACKAGED TERMINAL AIR CONDITIONER/HEAT PUMP INSTALLATION INSTRUCTIONS & OWNER'S MANUAL



ARAMA HEAT PUMP MODELS

DCIPT9
DCIPT12
DCIPT15

ATTENTION INSTALLATION PROFESSIONAL

As a professional installer you have an obligation to know the product better than the customer. This includes all safety precautions and related items.

Prior to actual installation, thoroughly familiarize yourself with this instruction manual. Pay special attention to all safety warnings.

Often during installation or repair it is possible to place yourself in a position which is more hazardous than when the unit is in operation.

Remember it is your responsibility to install the product safely and to know it well enough to be able to instruct a customer in its safe use.

Safety is a matter of common sense, a matter of thinking before acting. Most dealers have a list of specific good safety practices, follow them.

The precautions listed in this Installation Manual are intended as supplemental to existing practices. However, if there a direct conflict between existing practices and the content of this manual, the precautions listed here take precedence.

CONTENTS

UNIT FEATURES.....	2
INSTALLATION INSTRUCTION.....	4
WIRING.....	7
OPERATING INSTRUCTIONS (ACCESSORY OPTIONAL)	8
SENIOR OPERATION.....	9
FUNCTION OF DIP SWITCHES.....	10
MAINTENANCE AND CLEANING	11
NORMAL OPERATING SOUNDS AND CONDITION.....	13
DIAGNOSTIC CODES & SOLUTIONS.....	14
TROUBLESHOOTING.....	15

IMPORTANT NOTES:

Before using this manual, check the serial plate for proper model identification.

The installation and servicing of this equipment must be performed by qualified, experienced technicians only.

Due to policy of continual product improvement, the right is reserved to change specifications and design without notice.

IMPORTANT NOTICE TO THE OWNER

This manual is to be used by qualified, professionally trained HVAC technicians only. The manufacturer does not assume any responsibility for property damage or personal injury for improper service procedures or services performed by an unqualified Person.

IMPORTANT NOTICE TO THE OPERATOR/ENGINEER

Read this manual and familiarize yourself with the specific items which must be adhered to before attempting to service this unit. The precautions listed in this Installation Manual are intended as supplemental to existing practices. However, if there is a direct conflict between

THE FOLLOWING WARNINGS ARE VERY IMPORTANT FOR SAFETY. PLEASE READ THEM CAREFULLY BEFORE INSTALLATION!

1. The air conditioner must be installed by certificated installer. It's forbidden to install by those amateur.
2. Please check whether there is grounding wire in the power supply system before installation. If not, installers should refuse installing and explain the safety principle to users.
3. To avoid electric shock or even death, the socket or terminal blocks for power supply to the air conditioner(include 277V and 115V and 208~230V series and the units that have LCDI power cord) must connect a Ground Fault Circuit Interrupter.
4. During installation, the wire connection must strictly follow the rule which is zero line and fire line of unit should be connected to the zero line and fire line in the power system. The connection in reverse is forbidden. Please be sure the ground wire is firmly connected otherwise it is possible to result in the electrical shock or death.

RECOGNIZE THIS SYMBOL AS A SAFETY PRECAUTION

WARNING

THE MANUFACTURER WILL NOT BE RESPONSIBLE FOR ANY INJURY OR PROPERTY, DAMAGE ARISING FROM IMPROPER SERVICE OR SERVICE PROCEDURES. IF YOU INSTALL OR PERFORM SERVICE ON THIS UNIT, YOU ASSUME RESPONSIBILITY FOR ANY PERSONAL INJURY OR PROPERTY DAMAGE WHICH MAY RESULT, MANY JURISDICTIONS REQUIRE A LICENSE TO INSTALL OR SERVICE HEATING AND AIR CONDITIONING EQUIPMENT.

WARNING

HIGH VOLTAGE
DISCONNECT ALL POWER BEFORE SERVICING OR INSTALLING THIS UNIT. MULTIPLE POWER SOURCES MAY BE PRESENT, FAILURE TO DO SO MAY CAUSE PROPERTY DAMAGE, PERSONAL INJURY OR DEATH.

UNIT FEATURES

This unit has many features which are different from those found on conventional PTAC units. The operator must be familiar with these features in order to properly handle the unit.

- **DC-inverter compressor**—Manufactured by MITSUBISHI, due to its higher efficiency, energy saving up can be up to 30% to 80%. Operation voltage range is wider from 160VAC~270VAC, make sure unit operation more stable under wide voltage range power input. For its soft start feature, power surge can be avoided, and also lower the noise level. Without frequently start-stop makes the room temperature more stable, so more comfortable.
- **High performance IPM**—Containing PFC module, under heavy loading, PF can be up to 99%, thus decreases EMI pollution to power supply system, and also decreases power surge. Compressor driver chip is manufactured by FAIRCHILD, famous brand and high performance, making the compressor running more reliable and more stable.
- **LCDI Cords**—Underwriters Laboratories and the National Electric Code (NEC) now require power cords that sense current leakage and can open the electrical circuit to the unit on units rated at 250 volts or less. In the event that unit does not operate, check the reset button located on or near the head of the power cord as part of the normal troubleshooting procedure.

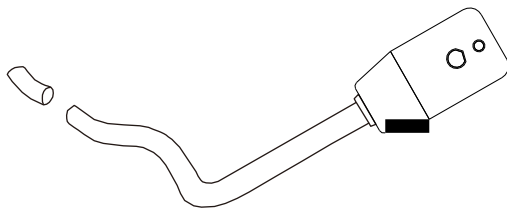

LCDI power Cord

- **Automatic 3-minute compressor lockout**—After the compressor cycles off, it will not restart for three minutes.
- **Random restart delay**—To help eliminate power surges after a power outage, the unit is equipped with a two to four minute random restart delay feature. Whenever the unit is plugged in with the master switch turned on and the mode switch set in the cool or heat mode, a random restart will occur. A random restart condition can be avoided by setting the mode switch in the fan only or off position before applying power to the unit.
- **Indication LEDs**—The control panel has LEDs that correspond to fan operation and to indicate unit status. The LEDs next to the selections ON/OFF, FAN, COOL, and HEAT indicate which operational mode is active.

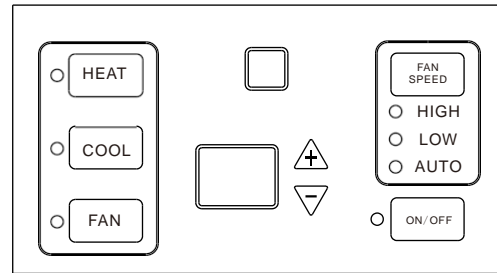

- **System safety protections**—To ensure the system running safely, electric control has the following protections, for problem solving, please refer to **diagnostic codes & solutions** and **troubleshooting** sections.

A) Outdoor unit overload protection in COOLING mode

When condenser coil temperature exceeds the presetting point, compressor decreases the operating frequency to 30Hz. If this protection is inactive and condenser coil temperature reaches the shut-down point, compressor will be turned off. Thus unit provide double protections.

B) Evaporator over cold protection (will not display error code)

When evaporator coil temperature drops to 1°C and lasts for 5 minutes, compressor and outdoor fan will stop, indoor fan keeps on running.

C) Compressor discharge over heat protection

When compressor discharge temperature reaches protection point, compressor will decrease operating frequency to 30Hz. If this protection is inactive and discharge temperature reaches the shut down point, compressor will be turned off. Thus provide double protections.

D) Evaporator overload protection in HEAT PUMP mode

When evaporator coil temperature exceeds the presetting point, compressor decreases the operating frequency to 30Hz. If this protection is inactive and evaporator coil temperature reaches the shut down point, compressor will be turned off. Thus provide double protections. This time the back up electric heater will be turned on.

E) Input over current protection

When input current exceeds the presetting point, compressor will decrease the operating frequency to 30Hz. If this protection is inactive and current reaches the shut down point, compressor will be turned off.

F) Compressor over current protection

When compressor operating current exceeds the shut down point, compressor will be shut down.

G) IPM fault protection

When IPM faults, include over heat, unit will be shut down, all outputs are terminated, control panel displays the error code.

H) Temperature sensor fault protection

Any temperature sensor faults, unit stops and display the error code.

I) Communication fault protection

For continuously 2 minutes communication faults between indoor unit and outdoor unit, unit will shut down and displays error code.

J) Compressor starting fault

If compressor starting fails, 3 minutes later, it will try to start again. It will not display error code at the first 3 times fault. If the 4th time fail again, it will not start any more and display the error code.

K) DC-BUS over voltage/under voltage protection

Once monitors the DC-BUS is over or under voltage, unit stops and display error code.

L) EEPROM fault

When the unit is powered on, if system monitors the EEPROM fault, displays error code and will not operate any more.

- **Intelligent control**-CPU will adjust the compressor operating frequency according to the energy demand, making the room temperature more stable and more comfortable and more energy saving.
- **Two-speed outdoor fan HIGH/LOW**-When outdoor ambient temperature becomes lower (for example, during the night), outdoor fan will operating in low speed, so to lower the noise and also more energy saving.
- **Standard Physical Dimensions**-The series PTAC is with the same dimensions 42" wide x 16" high x 13-3/4" deep

Replacement of older units is made easy.

- **Weather-Protected Electrical Components**-Vital electrical components are protected from the weather by locating them on the indoor side of the weather barrier.
- **Highly Featured Microprocessor Controls**-Microprocessor controls are programmed to interface with the temperature sensors to maximize comfort conditions for the room occupant and provide outstanding features.

Thermistors are used to sense small changes in temperature to give excellent room control and allow the microprocessor to monitor and react to changing conditions.

- **Automatic Emergency Heat on Heat Pump Units**-Automatically uses electric resistance heat if the heat pump fails .

- **Fan Motors Permanently Lubricated**-All units have two fan motors for quiet operation and maximum operating efficiency.

Motors are permanently lubricated to reduce maintenance and totally enclosed to keep dirt and water out of the motor windings.

- **Indoor Fan Speed Selections LOW /HIGH**-Unit may be operated in low fan speed or high fan speed. Some speed may not be present based on unit capacities.

- **LS Control(front-desk control)**-The unit can be turned ON/OFF by front-desk control switch.The control wire,colored purple,locates in the wall mounted thermostat interface(refer to Fig11 on page 7).

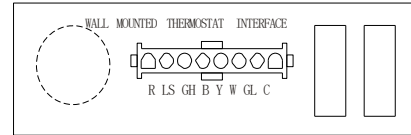

The control logic as below:

- 1.Turn ON unit:short circuit R and LS then release for one time within 5 seconds.
- 2.Turn OFF unit:short circuit R and LS then release for twice within 5 seconds.
- 3.Force unit shut down for one time:connect LS to R for over 5 seconds.

NOTE: After force shut down, you can turn the unit ON again by hand-held remote controller or the control panel.

⚠ WARNING

HIGH VOLTAGE
DISCONNECT ALL POWER BEFORE SERVICING OR INSTALLING THIS UNIT. MULTIPLE POWER SOURCES MAY BE PRESENT, FAILURE TO DO SO MAY CAUSE PROPERTY DAMAGE, PERSONAL INJURY OR DEATH.

UNIT ACCESSORIES

This unit is designed for through-the-wall installation in new or existing buildings. To complete the installation of this PTAC, an insulated wall sleeve and an outdoor grille (either the stamped aluminum grille, or the architectural grille) are required.

The chassis and the cabinet front are shipped in one carton. Optional accessories to complete a particular installation are the following:

OPTIONAL ACCESSORIES

- Wall Sleeve Kit
- Key Lock Kit
- Drain Kit
- Filter Kit
- Wire Harness Kit
- Architectural Grille Kit
- Stamped Louver Kit
- LCDI Power Cord
- Wireless IR Thermostat
- Electric And Non Electric Sub Base Kit
- IR REMOTE CONTROLLER

NOTE: Consult sales literature for the appropriate voltage and amperage selections, if applicable.

INSTALLATION INSTRUCTIONS

To ensure that the unit operates safely and efficiently, it must be installed, operated and maintained according to these installation and operating instructions and all local codes and ordinances or, in their absence, with the latest edition of the National Electric Code. The proper installation of this unit is described in the following sections. Following the steps in the order presented should ensure proper installation.

⚠ WARNING

HIGH VOLTAGE
DISCONNECT ALL POWER BEFORE SERVICING OR
INSTALLING THIS UNIT. MULTIPLE POWER SOURCES MAY
BE PRESENT, FAILURE TO DO SO MAY CAUSE PROPERTY
DAMAGE, PERSONAL INJURY OR DEATH.

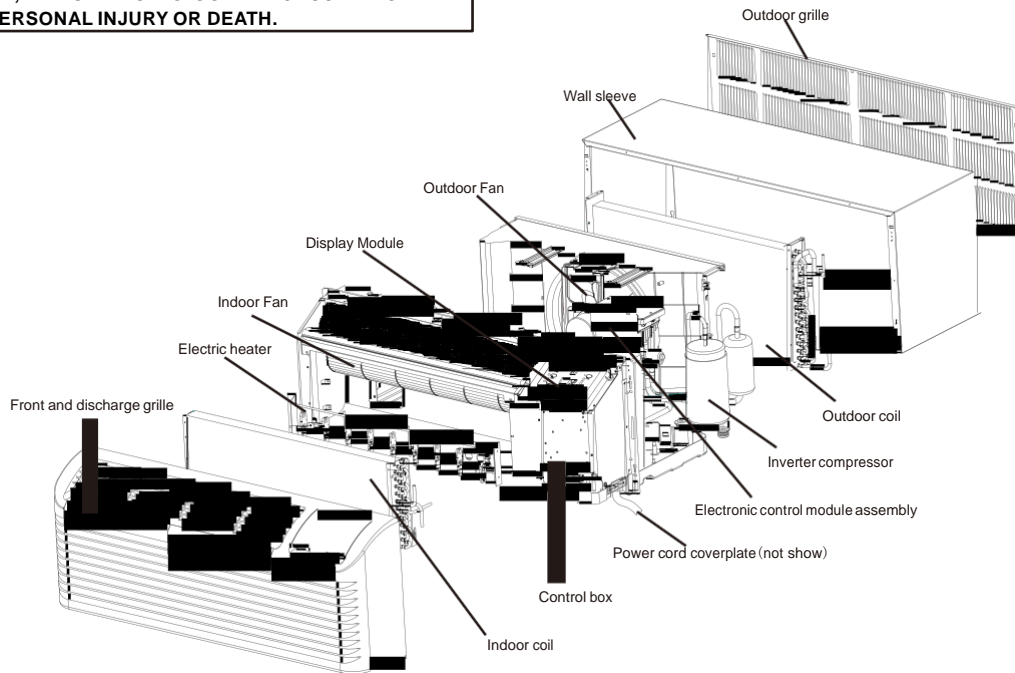

WALL SLEEVE ASSEMBLY (OPTIONAL ACCESSORY)

Two kinds of wall sleeve are optional for customers, one is reassemble wall sleeve and the other one is welding integrated wall sleeve.

Removable Wall Sleeve

The removable wall sleeve can be removed and occupies less space and is convenient to transport. Follow the below steps to install :

- a) Unpack all parts and accessories, referring to Fig 1.
- b) Assemble the wall sleeve by first “clip locking” the side pieces to the bottom piece.
- c) Assemble the top piece to the assembled side and top piece.

Welded integrated wall sleeve

Welded integrated wall sleeve is featured by artistic appearance and stable structure referring to Fig 2. Customers can purchase together with unit.

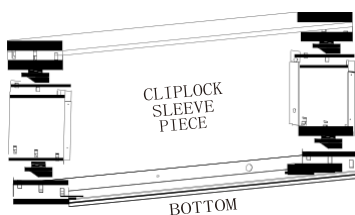

Fig 1

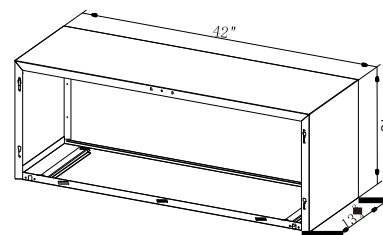

Fig 2

SLEEVE INSTALLATION

Wall sleeve location

When making the wall opening, please observe the following requirement:

- A) The air inlet and outlet should be unblocked and the air can be delivered to every corner of the room
- B) Install the unit in places that are away from heat source or sources of flammable gases.
- C) Do not install the unit in places that are subject to strong dust
- D) Do not install the unit in places where the operational noise and exhausted air might trouble your neighbour.
- E) There should be sufficient space margins around the unit to facilitate maintenance and repairs(refer to Figs 3 and 4)

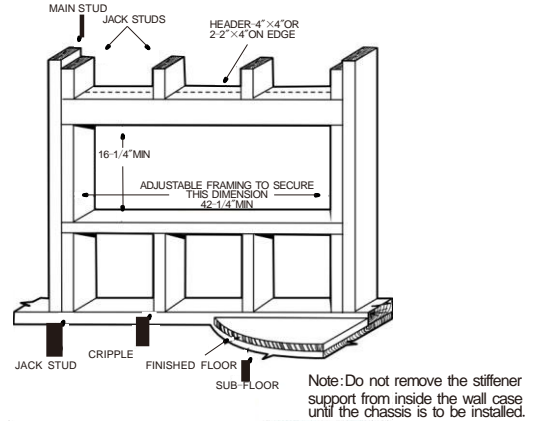

Fig 5

Chart 2

	minium finished opening dimensions		sleeve dimensions		
	Height	width	height	width	depth
NO. 1	16-1/4"	42-1/2"	16"	42"	13-3/4"
NO. 2	16-1/4"	42-1/4"			(16"/18"/24")

NOTE: NO. 1 means using field supplied sleeve angles
NO. 2 means not using field supplied sleeve angles

In order for condensate water to drain properly inside the unit, the sleeve must be installed properly:

- Level from right to left.
- A slight downward pitch from the indoor side to the out-door side as shown below (Fig 6) .
- Fasten the wall sleeve (Fig 7) .

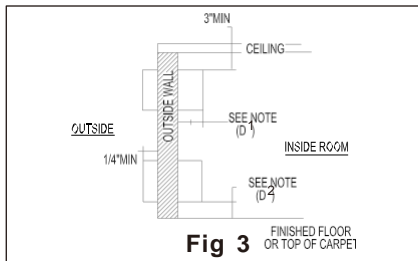

Fig 3

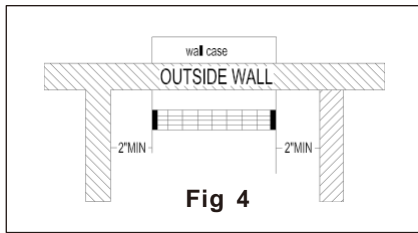

Fig 4

Chart 1

Dimensions	Recommended installation clearance
D1	Projection of case into room-1/2" minimum up to 1-3/4" maximum without use of electrical sub-base. Note: 2-3/8" minimum when sub-base is used.
D2	Height above finished floor or top of carpet-1/2" minimum, 2" recommended without sub-base-3" minimum with sub-base.

Preparation of the wall

The sleeve should be installed during construction and lintels should be used to support the block above the wall sleeve. The sleeve can not support the load of bricks/blocks.

For existing construction, wall opening must be created, the proper dimensions are necessary to avoid use of fillers or additional framing .The sleeve is modular in height and width(refer to Fig 5& Chart 2).

Height: Fits 2 courses
concrete block Fits 6 courses
standard brick Fits 5 courses
jumbo brick Width:

Fit approximately 3 stud spaces.

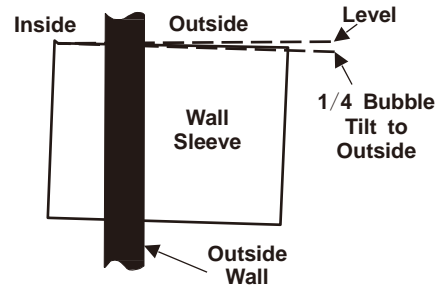

Fig 6 Proper Sleeve Tilt

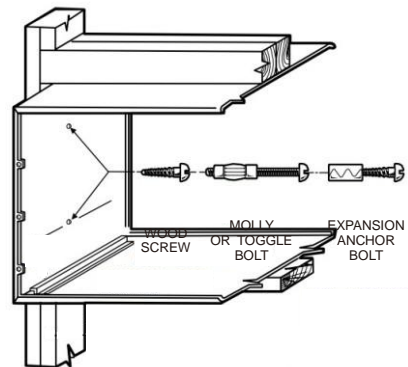

Fig 7

OUTDOOR GRILLE(OPTIONAL ACCESSORY)

An outside grille must be installed to direct air flow for proper unit operation and also protect the outdoor coil. The grille must be installed before installing the chassis.

When replacing an old chassis with an existing grille or using a specialized grille in a new installation, please check with after-sales engineer of supplier to determine if the new chassis should be used with the nonstandard specialized grille. An improper outdoor grille can decrease cooling or heating capacity, increase energy usage and shorten compressor life and possibly void the warranty.

Flush Stamped Louver

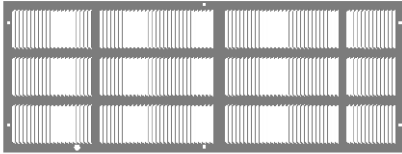

Architectural Louver



CHASSIS INSTALLATION

1. Remove the cabinet front from the chassis as described in Front Removal.
2. Insert the chassis into the wall sleeve.

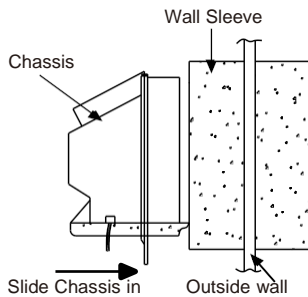

Chassis Installation View 1

3. Slide the chassis into the wall sleeve until the chassis flanges contact the front edge of the wall sleeve.

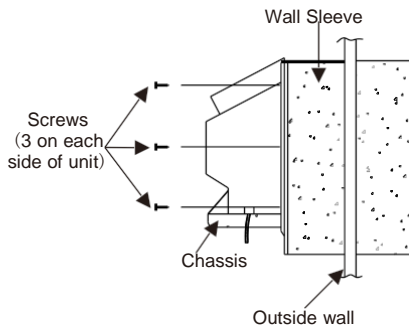

Chassis Installation View 2

4. Secure the chassis to the wall sleeve using three screws on each side of the chassis to ensure a proper seal between the chassis and the wall sleeve. The screws are supplied in a plastic bag.

IMPORTANT NOTES:

1. The unit is equipped with a rubber grommet mounted compressor. These grommets are factory set and require no adjustment.
2. Check the indoor and outdoor grilles for obstructions to air flow. The unit must be located where curtains, furniture, trees, or other objects do not block the air flow to and from the unit. If air is obstructed and/or deflected back into the unit, the air conditioner compressor may cycle on and off rapidly. This could damage the compressor or possibly void the warranty.

FRONT REMOVAL

1. Grasp the cabinet front.

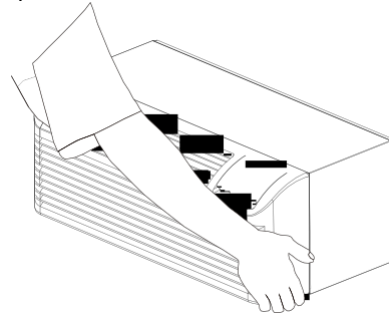

Cabinet Front Removal View 1

2. Pull the bottom of the cabinet front away from the chassis until the retaining clips disengage.

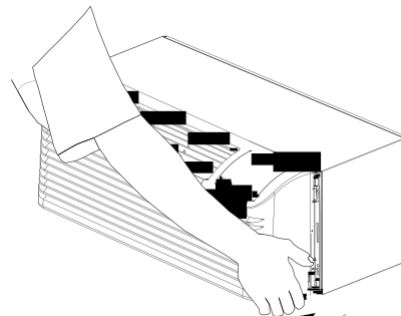

Cabinet Front Removal View 2

3. Lift the cabinet front off the chassis. Reverse this procedure to reinstall the cabinet front

WIRING

230~208V units are equipped with LCDI power cords and can open the electrical circuit to the unit. In the event the unit does not operate, check the reset button located on or near the head of the power cord as part of the normal troubleshooting procedure.

⚠ WARNING

HIGH VOLTAGE
 DISCONNECT ALL POWER BEFORE SERVICING OR INSTALLING THIS UNIT. MULTIPLE POWER SOURCES BE PRESENT, FAILURE TO DO SO MAY CAUSE PROPERTY DAMAGE, PERSONAL INJURY OR DEATH.
 DO NOT SERVICE THIS UNIT WITHOUT FIRST SHUTTING OFF THE POWER TO THE UNIT FROM THE CIRCUIT BREAKER AND/OR REMOVING THE UNIT CORD SET PLUG FROM THE WALL OUTLET.

⚠ WARNING

TO AVOID THE RISK OF PROPERTY DAMAGE, PERSONAL INJURY OR FIRE, USE ONLY COPPER CONDUCTORS.

⚠ WARNING

TO AVOID PROPERTY DAMAGE, PERSONAL INJURY OR DEATH DUE TO ELECTRICAL SHOCK, DO NOT USE AN EXTENSION CORD WITH THIS UNIT.

⚠ WARNING

TO AVOID THE RISK OF PROPERTY DAMAGE, PERSONAL INJURY OR FIRE DO NOT INSTALL WITH POWER CORD STRETCHED OR UNDER A STRAIN AS THIS MAY CREATE LOOSE PLUG/RECEPTACLE CONNECTION.

⚠ WARNING

TO AVOID THE RISK OF PERSONAL INJURY, WIRING TO THE UNIT MUST BE PROPERLY POLARIZED AND GROUNDED.

⚠ WARNING

THIS AIR CONDITIONER IS NOT MEANT TO PROVIDE UNATTENDED COOLING OR LIFE SUPPORT FOR PERSONS OR ANIMALS WHO ARE UNABLE REACT TO THE FAILURE OF THIS PRODUCT.
 THE FAILURE OF AN UNATTENDED AIR CONDITIONER MAY RESULT IN EXTREME HEAT IN THE CONDITIONED SPACE CAUSING OVERHEATING OR DEATH OF PERSONS OR ANIMALS.

VOLTAGE MEASUREMENTS

Once the unit is properly wired, measure the unit supply voltage. Voltage must fall within the voltage utilization range given in Chart 3.

Operating Voltage		
Unit Voltage	Voltage Utilization Range	
Rating	Minimum	Maximum
230/208	197	253

Chart 3 -Operating Voltage

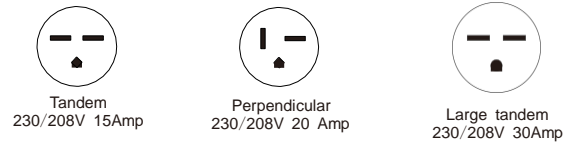
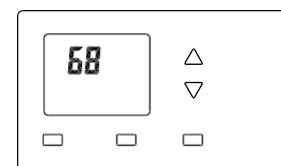
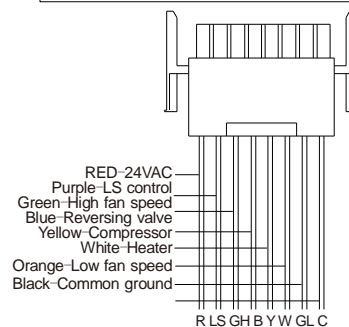
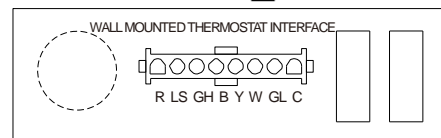
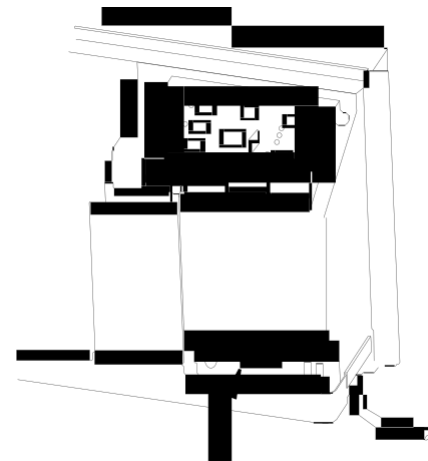

Fig 8 Receptacles/Sub-bases



Thermostat

Fig 9 wall mounted thermostat wiring

NOTE: See the "Remote Thermostat Change" instructions before use the thermostat.

OPERATING INSTRUCTIONS (ACCESSORY OPTIONAL)

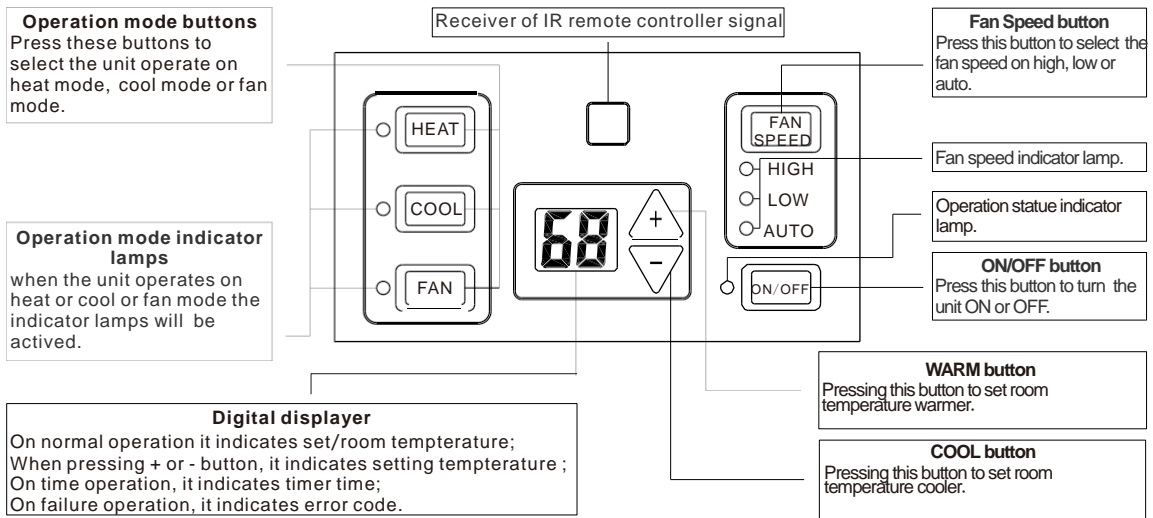

Fig 10 Use of unit mounted control panel

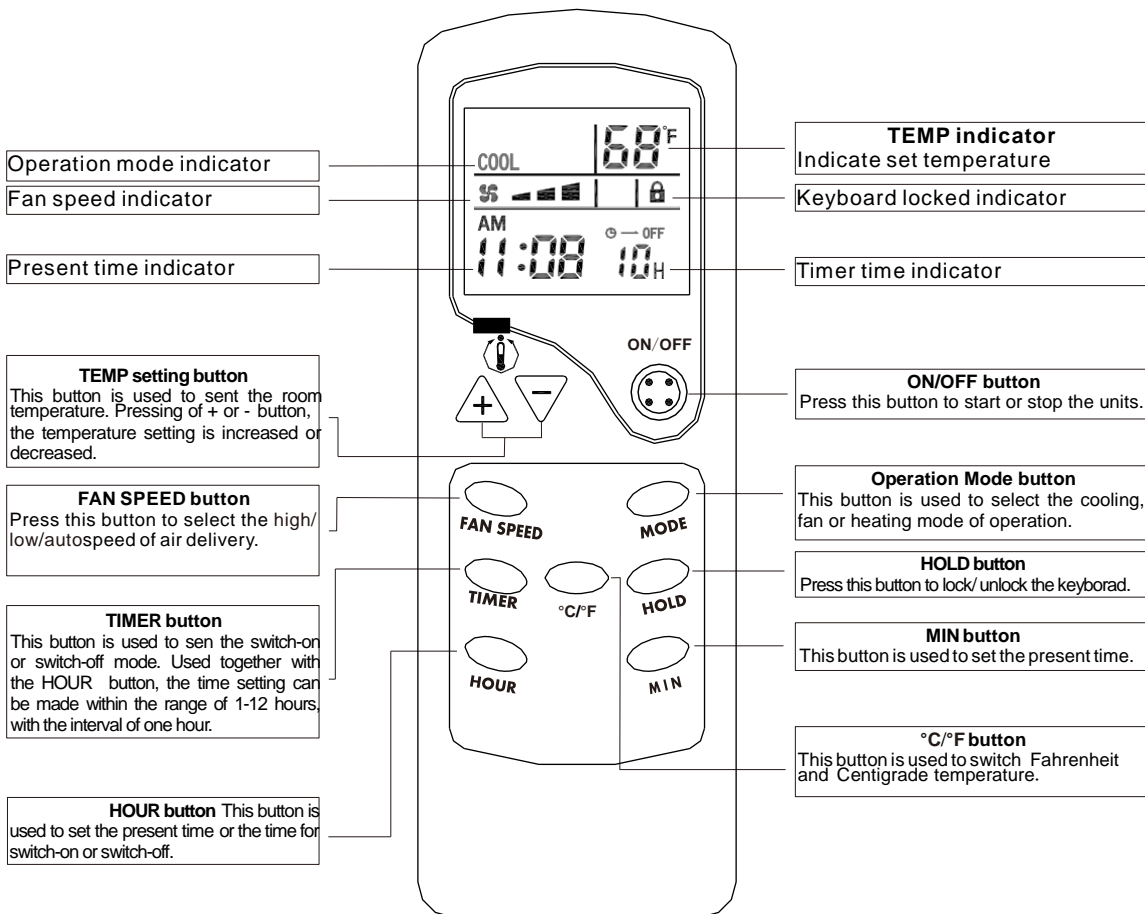

Fig 11 Use of hand held remote controller

COOL/FAN/HEAT MODE OPERATION PROCEDURE

Control panel:

- 1 Press the ON/OFF button.
- 1 Press the HEAT/COOL/FAN button, select the operation mode: heat/cool/fan.
- 1 Press + or - button, to set your desired temperature. The setting temperature range is 60-90°F(16-32°C).
- 1 Press the FAN SPEED button, to set your desired air flow rate: high/ low/auto.

Remote controller:

- 1 Press the ON/OFF button with the remote controller pointing toward the packaged terminal air conditioner.
- 1 Press the MODE button, select the operation mode: cool/fan/heat.
- 1 Press + or - button, to set your desired temperature. The setting temperature range is 61-88°F(16-31°C).
- 1 Press the FAN SPEED button, to set your desired air flow rate:hig/ low/auto.

TIMER PROCEDURE (Remote controller)

When cells are inserted, the present time is automatically set to AM 0:00.EX.:set to AM 10:30.

- 1 Open the back cover, push the CLK button .The time indicator is flickering and can set the present time.
- 1 Press the HOUR button.(set to AM 10:00)
- 1 Press the MIN button.(set to 30)
- 1 Press the CLK button again, and then close the back cover.

NOTE: For some type, this function may be not exist.

SENIOR OPERATION

Under OFF mode, hold [COOL] and [FAN SPEED] two keys at the same time continuously for **5** seconds. This time display 'd0', indicates that system has entered the senior operation status.

[COOL] key is used to switch parameter code and parameter value;

[+] or **[-]** keys are used to switch parameter code or set parameter value;

[ON/OFF] key is used to save and exit settings.

d4	Indoor temperature calibration	-9°C to 9°C	If unit of temperature is changed calibration should be done again If use the default value, it can be ignored. (default 0°C/0°F)
		-9°F to 9°F	
d5	Temperature display selection	0 or 1	1 indicates displaying room temperature, 0 for setting point (default 0)

One setting example: Setting target: d0(C), d1(r), d2(30°C),d3(18°C),d4(-1°C),d5(1).

Step1: hold [COOL] and [FAN SPEED] two keys at the same time continuously for 5 seconds.

Display:'d0' Step2: short press

[COOL] key. Display:'F'

Step3: short press [+] or [-] key.

Display:'C' (setting d0 has finished)

Step4: short press [COOL] key.

Display:'d0' Step5: short press [+]

key. Display:'d1' Step6: short press

[COOL] key. Display:'P'

Step7: short press [+] or [-] key.

Display:'r' (setting d1 has finished)

Step8: short press [COOL] key.

Display:'d1' Step9: short press [+]

key. Display:'d2' Step10: short

press [COOL] key. Display:'32'

Step11: short press [-] key twice.

Display:'30' (setting d2 has finished)

Step12: short press [COOL] key.

Display:'d2' Step13: short press [+]

key. Display:'d3' Step14: short press

[COOL] key. Display:'16' Step15:

short press [+] key twice. Display:'18'

(setting d3 has finished) Setp16:

short press [COOL] key. Display:'d3'

Step17: short press [+] key.

Display:'d4' Setp18: short press

[COOL] key. Display:'0'

Parameter code	Function	Parameter value	Explanation
d0	Unit of temperature	F	Fahrenheit(default)
		C	Celsius
d1	Operation way selection	P	By control panel or IR remote thermostat (default)
		r	By 24V universal remote thermostat
d2	Top temperature setting	d3 to 32°C/90°F	The minimum value is d2 (default 32°C/90°F)
d3	Bottom temperature setting	16°C/60°F to d2	The maximum value is d3 (default 16°C/90°F)

- Step19: short press [-] key.
 Display: '-1' (setting d4 has finished)
 Step20: short press [COOL] key.
 Display: 'd4'
 Step21: short press [+] key.
 Display: 'd5'
 Step22: short press [COOL] key.
 Display: '0'
 Step23: short press [+] or [-] key.
 Display: '1' (setting d5 has finished)
 Step24: short press [ON/OFF] key to save and exit settings.

FUNCTION OF DIP SWITCHES (putting to ON position makes the function active)

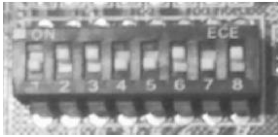

- #1 Reserved
- #2 Heat pump-It must match the module, forbidden changing the default setting
- #3 Electric heater-It must match the module, forbidden changing the default setting
- #4 Reserved
- #5 Freeze protection-Default setting is ON.

When room temperature is lower than 10°C(50°F) continuously for 3 minutes, unit (except the cooling only type) will start heating automatically. Only when room temperature reaches 13°C(55°F) will heating be stopped.

If this switch is put to OFF position, it will be no freeze protection.

- #6 Electric memory-Default setting is ON.

If the unit is cut out of power during the operation, when it is powered up again, all last settings will be remembered, and the operation will follow the last mode. Manual turn on the unit, operation mode will be the last settings.

If this switch is put to OFF position, it will be no memory.

- #7 Fan CON/CYC for heating-Default setting is OFF(indoor fan cycles running).

In heating mode when compressor is OFF, indoor fan will be OFF too.

If this this switch is put to ON position, even compressor is OFF, indoor fan will continuously running.

- #8 Fan CYC/CON for cooling- Default setting is OFF(indoor fan continuous running). In cooling mode when compressor is OFF, indoor fan will continuously run. If this switch is put to ON position, when compressor is OFF, indoor fan will be OFF .

VENTILATION CONTROL

The ventilation control lever is located at left side of unit, behind front panel.

NOTE: The vent door shipping tape must be removed before using vent control lever. See Fig 12 and Fig13.

When set at close, only the air inside the room is circulated and filtered;

When set at open, some outdoor air will be drawn into room, this will reduce heating or cooling efficiency.

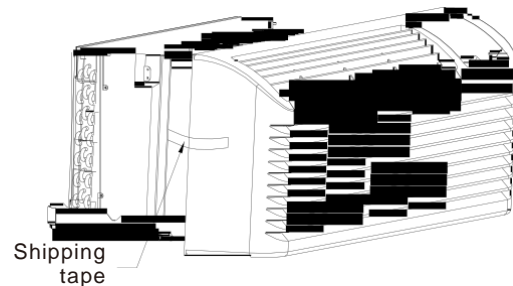

Fig 12 Shipping tape Location

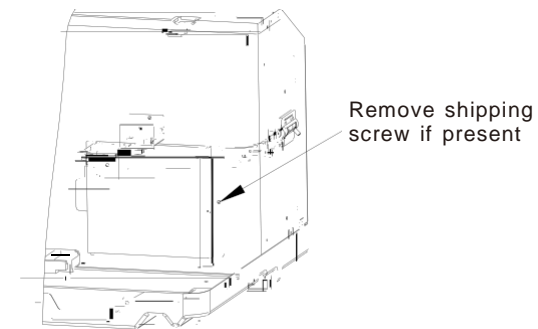

Fig 13 Shipping Screw Location

The vent control allows outside air to be drawn into the conditioned area. This outside air can provide ventilation when the blower is operating, but it will increase the heating or cooling load and operating costs.

To obtain access to the vent control

1. Remove the cabinet front (see Front Removal).
2. Remove the shipping screw (if installed) from the vent door.
3. Remove the label (if present) from over the vent control lever on the left side of the chassis. Remove the vent door shipping screw.
4. Rotate the vent control lever to either open or close the damper.

⚠ WARNING

HIGH VOLTAGE
DISCONNECT ALL POWER BEFORE SERVICING OR INSTALLING THIS UNIT. MULTIPLE POWER SOURCES BE PRESENT, FAILURE TO DO SO MAY CAUSE PROPERTY DAMAGE, PERSONAL INJURY OR DEATH.

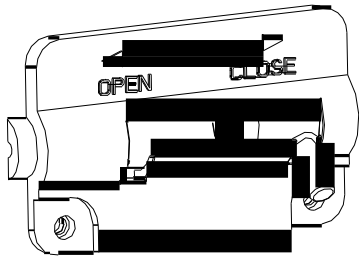
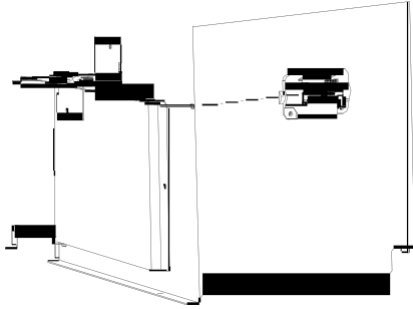

Vent door lever positions

AIR DISCHARGE GRILLE

The discharge grille can be adjusted to expel air at either a 15° or 55° angle.

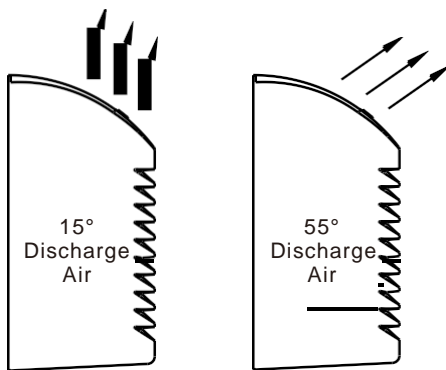

Discharge Grille Orientation Options

Use the following procedure to change the angle of the discharge air flow:

1. Remove the front cabinet (see Front Removal).
2. Position the front so that the backside is accessible.

Discharge Air Flow

3. Remove the seven (7) screws which secure the discharge air grille to the cabinet front.

Location of 7 Screws

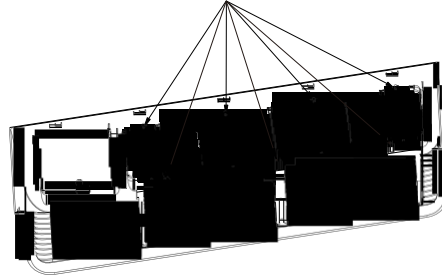

Discharge Air Flow Grille Removal

4. Rotate the grille 180° clockwise
5. Reinstall the screws securing the discharge air grille to the cabinet front. Reinstall the cabinet front on the unit.

MAINTENANCE AND CLEANING

⚠ WARNING

HIGH VOLTAGE
DISCONNECT ALL POWER BEFORE SERVICING OR INSTALLING THIS UNIT. MULTIPLE POWER SOURCES BE PRESENT, FAILURE TO DO SO MAY CAUSE PROPERTY DAMAGE, PERSONAL INJURY OR DEATH.

MONTHLY MAINTENANCE AND CLEANING

Intake Air Filters

To properly maintain the operational performance of your PTAC unit, it is extremely important that the inlet air filters be cleaned once per month or more often if operated in dusty or dirty locations or conditions. The intake air filters are constructed of durable polypropylene. The "air intake" air filters can be easily inserted into the cabinet front, using the filter guides. Before cleaning the intake filter, turn the unit off by setting the mode switch to the OFF position. Filter should be cleaned as required.

The following procedure is used to remove the intake filter:

1. Grasp each filter by its molded handle, located on the front edge of the front, below the discharge grill.

2. Pull the filter straight up and remove.
3. Clean filter with vacuum or with running water.

Reverse this procedure to reinstall the filter.

Filter is removed by grasping the filter's top and gently pulling up

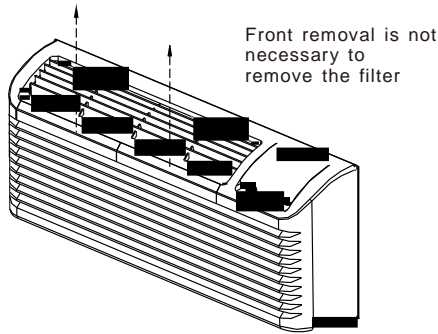

Vent Screen

Before cleaning the vent screen, disconnect power to the unit by unplugging the power cord at the wall outlet or subbase, or disconnect power at the fuse box or circuit breaker. If unit is operated with vent door closed, the vent screen does not need

to be cleaned.

1. Remove the cabinet front as described in Front Removal.
2. Remove the six screws securing the chassis to the wall sleeve.
3. Slide the chassis out of the wall sleeve far enough so that the vent screen is accessible.
4. Clean the vent screen, slide the chassis back into the wall sleeve, secure it in place with six screws and reinstall the front cabinet.

Cabinet Front

The cabinet front and discharge air grille can be cleaned with a water dampened cloth. Under no circumstances should hydrocarbon-based cleaners (e.g. acetone, benzene, naphtha gasoline, etc.) or ammonia based cleaners be used to clean the front or air grilles. Use care when cleaning the control area.

YEARLY MAINTENANCE AND CLEANING

NOTE: Use a mild biodegradable detergent when cleaning the unit. Special care must be taken to protect the unit's control board and other electrical components from getting any water on them while cleaning. The use of harsh or caustic cleaning agents or materials such as bleach or coil cleaners that are not designed for PTAC products will cause damage or deterioration of the aluminum fin or coil material and is not recommended. Care must be taken not to bend the aluminum fin stock.

Routine scheduled Maintenance

To achieve continuing top performance and high efficiency, establish a "once a year" cleaning/inspection schedule for the unit. Take the unit out of the sleeve and thoroughly clean and rinse. Be sure to include in the yearly cleaning the evaporator coil, and condenser coil, basepan, and drain passages.

Scheduled maintenance can be accomplished by either qualified local maintenance staff or by an authorized servicer. They must follow the instructions described in this manual.

Adverse Operating Conditions Maintenance

Units operating in dusty or corrosive locations; i.e. dusty construction site or sea coast, must be cleaned more often. A minimum of four (4) times a year will maintain proper operational conditions and protect unit components.

Wall sleeve

Clean the wall sleeve while cleaning the unit. The caulking around the sleeve should be checked to make sure that any potential air and water openings around the sleeve are properly sealed. The wall sleeve's level should also be rechecked. Proper leveling for most installations are a 1/4 bubble tilt to the outside and level from right to left. Contact your sales person for detailed maintenance or cleaning instructions.

⚠ CAUTION!

DO NOT USE COMMERCIAL GRADE COIL CLEANERS. SOME OF THESE CLEANERS MAY CONTAIN ETHYLENE DIAMINE TETRACETIC ACID (EDTA) WHICH CAN SHORTEN THE LIFE OF THE CONDENSER COIL.

Base pan and Condenser coil

Before cleaning the base pan and condenser coil, turn OFF unit mode switch and disconnect power to the unit.

To disconnect power, either unplug the power cord at the wall outlet or subbase, or disconnect power at the fuse box or circuit breaker

1. Create a water tight seal by tightly covering the entire control panel area and fan motor with plastic. Creating this seal prevents water from entering the control area or the fan motor and damaging the unit.
2. Spray condenser coil and base pan down with water. Next spray a mild biodegradable detergent onto the condenser coil and base pan. Let set for five (5) minutes.
3. Rinse condenser coil and base pan with water again.

NOTE: Ensure water pressure is no higher than that of an ordinary garden hose and the water temperature no higher than 120°F.

4. Tilt the non-compressor side of the unit up no higher than 45 degrees and allow water to drain out the other side of the unit.
5. Remove excess water left in the base pan by wiping the base pan with a dry cloth.
6. Remove the water-tight seal from the motor and control panel area.
7. Reinstall unit back into wall sleeve.
8. Allow unit to dry for 24 hours before reapplying power. When power is reapplied test unit for proper operation.
9. Place a non-acidic algaecide in the base pan to inhibit bacteria growth. Ensure the algaecide is compatible with wet coil operation and is not corrosive to the coil.

⚠ CAUTION!

HIGH PRESSURE AND HIGH TEMPERATURE CLEANING IS NOT RECOMMENDED. DOING SO COULD DAMAGE THE ALUMINUM FIN STOCK AND ELECTRICAL COMPONENT.

Clearance Check

Clearances around the unit should also be checked to make sure that the intake air and discharge air paths have not become blocked or restricted. A minimum of eight inches clearance is needed from unit to furniture, beds, or other objects for proper operation. Restricted discharge or intake air will reduce the unit's operational performance. In severe airflow restrictions damage can occur to unit components such as the compressor, electric heater or fan motor.

NORMAL OPERATING SOUNDS AND CONDITIONS

Water trickling sounds

Water is picked up and distributed over the coil. This improves the efficiency and helps with water removal.

Water dripping

Water will collect in the base pan during high humidity days. This can cause overflow and drip from the outside of the unit.

Air sounds

The fan cycle switch sets the operational mode of the fan. In the ON position the fan will run continuously whenever power is applied in this mode. In the AUTO position, the fan will cycle on and off with the compressor or electric heater.

Starting delay

You may notice a few minutes delay in the starting if you try to restart the unit too soon after turning it off or if you adjust the thermostat right after the compressor has shut off. This is due to a built-in delay to protect the compressor.

Buzzer Response

The buzzer will chime "Di"(0.1 sec) as response when receiving the effective order from key pad control and remote control.

DIAGNOSTIC CODES & SOLUTIONS

The Diagnostic Maintenance provides detailed information on PTAC control operation and operational status including present modes, failures, airflow restriction warnings, operating temperatures, and past failures.

Failure code	Content of defect	Solutions
E1	Communication failure between indoor unit and outdoor unit	Check the communication cables, make sure they are firmly connected. If the cables are broken, replace them.
E2	Indoor ambient temperature sensor fault	Check the sensor's plug is firmly connected. If the sensor is broken, replace it.
E3	Indoor coil temperature sensor fault	Check the sensor's plug is firmly connected. If the sensor is broken, replace it.
E4	Indoor outlet temperature sensor failure or Indoor outlet air over heat protection in Electric heating mode	Check if the indoor fan is running good and make sure no obstacle that blocks the air circulation. Check the sensor's plug is firmly connected. If the sensor is broken, replace it.
E5	IPM protection, include heat sink over heat protection	Make sure indoor and outdoor units vents are not blocked, indoor fan and outdoor fan are running well and compressor will not overload. After removing any fault, power the unit on again for rest.
E6	Outdoor ambient temperature sensor fault	Check the sensor's plug is firmly connected. If the sensor is broken, replace it.
E7	Outdoor coil temperature sensor fault	Check the sensor's plug is firmly connected. If the sensor is broken, replace it.
E9	Compressor discharge temperature fault	Check the sensor's plug is firmly connected. If the sensor is broken, replace it.
EC	DC compressor starting failure or compressor driving fault	Check the DIP switches on the main board (3-position, in red color) is correct, it must matches the wiring diagram. Make sure the compressor power wires is firmly connected.
EH	Indoor EEPROM fault, include EEPROM communication fault or data verification error	Check the EEPROM chip is firmly plugged. If still not solve, replace the chip.
P1	Over heat at indoor coil protection in HEATING (overload in heating). Over heat at outdoor coil protection in COOLING (overload at cooling).	Make sure indoor and outdoor unit vents are not blocked and indoor fan and outdoor fan are both working well. Clear the air filter and the condenser after a long time use.
P2	DC inverter module overheat, over current protection	Make sure indoor and outdoor unit vents are not blocked and indoor fan and outdoor fan are both working well. Check the DIP switch on the main board (3-position, in red color) is correct, it must matches the wiring diagram. Make sure the compressor power wires is firmly connected.
P4	Compressor discharge overheat protection (or compressor overheat)	Make sure indoor and outdoor unit vents are not blocked and indoor fan and outdoor fan are both working well. Check the DIP switch on the main board (3-position, in red color) is correct, it must matches the wiring diagram.
P7	Over voltage or under voltage protection	Make sure the power supply is within the requirement (AC208/230V -15%+10%) .If power supply is OK, but still not solved, replace the inverter IPM.

TROUBLESHOOTING

POSSIBLE CAUSES	SOLUTIONS
<p>UNIT DOES NOT START</p> <ul style="list-style-type: none"> • Unit may have become unplugged • Fuse may have blown • Circuit breaker may have been tripped • Unit may be off or in wall thermostat mode. <p>Check section on SENIOR OPERATION to verify dipswitches are set properly.</p> <ul style="list-style-type: none"> • Unit may be in a protection or diagnostic failure mode. See section on diagnostic codes. 	<ul style="list-style-type: none"> • Check that plug is plugged securely in wall receptacle. <p>Note : Plug has a test/reset button on it. Make sure that the plug has not tripped.</p> <ul style="list-style-type: none"> • Replace the fuse. • Reset circuit breaker. • Turn unit on (bottom right button on keypad). <p>Note: If the unit turns on, the LED will be green. If the unit is off, the LED will be red. If there is no LED on, there is a problem with power or damage to the control.</p>
<p>DISPLAY HAS STRANGE NUMBERS/CHARACTERS ON IT</p>	<ul style="list-style-type: none"> • The unit may be in a diagnostic condition. Check diagnostic codes --- checking Control section to determine if unit has had a failure. • The unit may be set for ° C (instead of ° F), see the SENIOR OPERATION.
<p>UNIT MAKING NOISES</p>	<ul style="list-style-type: none"> • Clicking, gurgling and whooshing noises are normal during operation of unit.
<p>UNIT NOT COOLING / HEATING ROOM</p> <ul style="list-style-type: none"> • Unit air discharge section is blocked • Temperature setting is not high or low enough <p>Note: Setpoint limits may not allow the unit to heat or cool the room to the temperature desired. Check section on dipswitch settings.</p> <ul style="list-style-type: none"> • Unit air filters are dirty. • Room is excessively hot or cold when unit is started • Vent door left open • Unit may be in a protection or diagnostic failure mode. Check section on Intelligent Self --- checking Control. • Compressor is in time delay. There is a protective time delay (approx . 3 minutes) on starting the compressor after a power outage(or restarting after it has been turned off), to prevent tripping of the compressor overload. 	<ul style="list-style-type: none"> • Make sure that curtains, blinds or furniture are not restricting or blocking unit airflow. • Reset to a lower or higher temperature setting. • Remove and clean filters. • Allow sufficient amount of time for unit to heat or cool the room. <p>Start heating or cooling early before outdoor temperature, cooking heat or gatherings of people make room uncomfortable.</p> <ul style="list-style-type: none"> • Close vent door. • Check dipswitch settings for desired comfort. • Wait approximately 3 minutes for compressor to start
<p>WATER DRIPPING OUTSIDE</p>	<ul style="list-style-type: none"> • If a drain kit has not been installed, condensation run off during very hot and humid weather is normal. See Note 2. If a drain kit has been installed and is connected to a drain system, check gaskets and fittings around drain for leaks and plugs.
<p>WATER DRIPPING INSIDE</p> <ul style="list-style-type: none"> • Wall sleeve is not installed level 	<ul style="list-style-type: none"> • Wall sleeve must be installed level for proper drainage of condensation. Check that installation is level and make any necessary adjustments.
<p>ICE OR FROST FORMS ON INDOOR COIL</p> <ul style="list-style-type: none"> • Low outdoor temperature • Dirty filters 	<ul style="list-style-type: none"> • When outdoor temperature is approximately 55°F (12.8°C) or below, frost may form on the indoor coil when unit is in Cooling mode. Switch unit to FAN operation until ice or frost melts. • Remove and clean filters.
<p>COMPRESSOR PROTECTION</p> <ul style="list-style-type: none"> • Power may have cycled, so compressor is in a restart protection. 	<ul style="list-style-type: none"> • Random Compressor restart—Whenever the unit is plugged in, or power has been restarted, a random compressor restart will occur. After a power outage, the compressor will restart after approximately 3 minutes. • Compressor Protection — To prevent short cycling of the compressor, there is a random startup delay of 3 minutes and a minimum compressor run time of 3 minutes